

ARCBRO®

Spark SERIES

CNC Plate Cutting Machine Installation Manual



Operator Manual

ARCBRO | Revision 2 |

English Date of issue:

August, 2021

Unique Solution

WWW.ARCBRO.COM

Technical Support

Thank you very much to choose ARCBRO product, our whole engineer department work for you since the day you receive machine. When you have any questions during assembling or operating, it is free to contact us by Call, Email, Online help 7x24 hours.

Wish you enjoy a wonderful CNC cutting travel.

ARCBRO CNC Technical Support & Solutions
7x24 Hours
+86-10-65798995
support@arcbro.com

www.arcbro.com/about-arcbro-cnc-cutting-solutions/



MACHINE ▾ PLASMA/FLAME CUTTER ▾ BLOG ▾ SUPPORT ▾ ABOUT US ▾ 🔍

Contact

by arcbro / August 7, 2015

Contact Us for CNC solutions



E-mail: Please leave message to us by live chat —

>>

Contact ARCBRO Portable CNC Cutting Machine

We will reply as soon as possible



Address: Xinfang Industrial Park, No.218, ChaoYang District, Beijing 100024, China

Tel: 0086 10 65798995

Fax: 0086 10 65790867

Share this:



Our System

- Contact
- Why ARCBRO

7/24 Hours Te

Any question, an

Tel: +86-17610780555

Email: info@arcbro.com

Follow Us



Installation steps

Basic logic: Follow the Number of each Parts to install.

I:Leg installation.



Step1:Connect the reinforcing plate to the 2 legs.



Step2:Attach the reinforcing plate and legs with screws.



Step3: Install the legs in order.

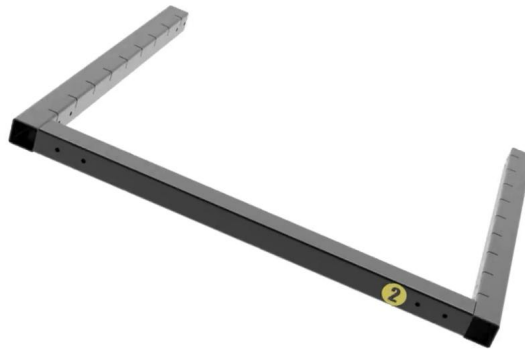

Step4: Arrange the frames in reverse.



Step5: Place the seal on the frame and then secure the frame seal and frame with a seal.



Step6: Place the finished frame on the finished leg frame and place the right angle support into 2 corners.



Step7: Place the main frame on the installed frame and secure with M8130mm.



Step8: Rotate the beam for 90° and secure the upper 4 screws first.

Service Support Spirit

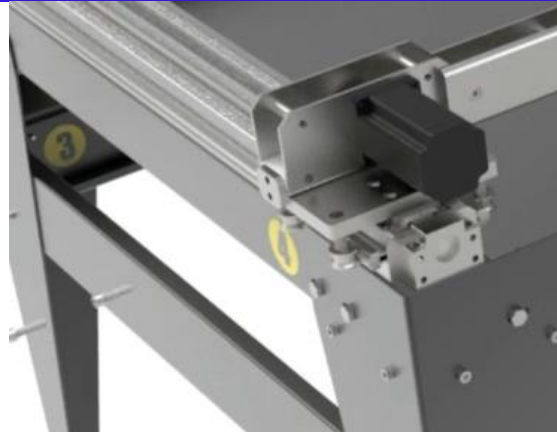

Step9: Place the processing plate to the beam side and fix it with screws to secure the lower side on top first.



Step10: Position the support frame to the machine side and secure.



Step11: Hold the grip well.